

PTFE-LINED BUTTERFLY VALVE T 211-A

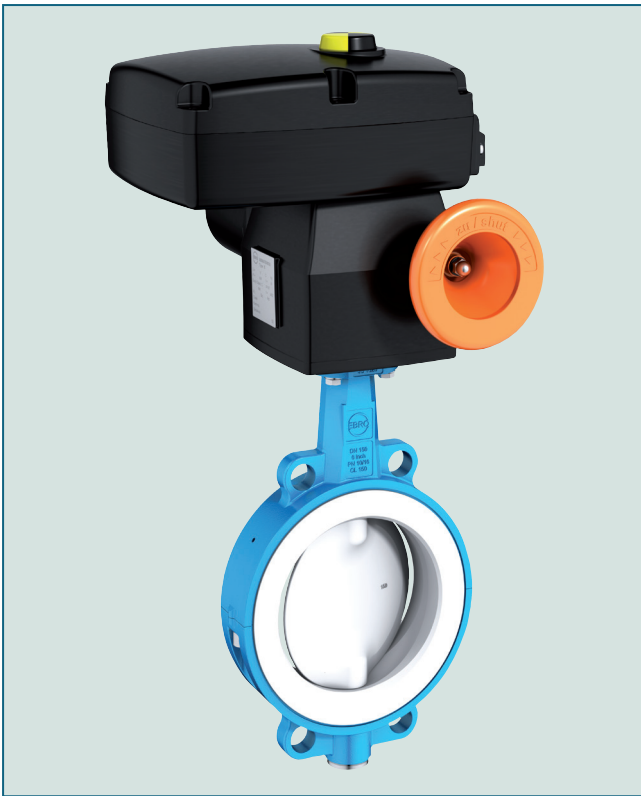

Fully PTFE-lined wafer type valve for corrosive and aggressive media. The patented shaft seal design ensures reliability even with high-corrosive applications.

FEATURES

- PTFE-lined butterfly valve for chemically toxic and highly corrosive media
- Environmental protection via EBRO-Safety seal
- Splitted body design
- Isolation height according to plant prescription
- Can be installed in any desired position
- Maintenance-free
- Can be disassembled, material-specific recycling possible
- Material conform to FDA EG 1935/2004
- Optional: Special design RWTÜV certified to TA-Air/ VDI 2440

GENERAL APPLICATIONS

- Chemically highly corrosive and toxic media
- Purification plants
- Pharmaceutical industry
- Adhesives, paper industry, dissolver
- Paint manufacture and processing
- Food industry
- Transport of hazardous materials (EN 14432)
- Chlorine production
- Processing of ore

TECHNICAL DATA

Nominal diameter:	DN(40) 50 - DN 300
Face-to-face:	EN 558 Series 20 ISO 5752 Series 20 API 609 Table 1
Flange accommodation:	EN 1092 PN 10/16 ASME Class 150 AS 4087
Flange Surface Design:	EN 1092 Form A/B ASME RF, FF
Top flange:	EN ISO 5211
Marking:	EN 19
Tightness check:	EN 12266 (Leakage rate A)
Temperature range:	-40°C to +200°C (depending on operation pressure)
Operating pressure:	max. 10 bar (16 bar for special version)
Vacuum:	up to 1 mbar absolute (with silicon elastomer inserts) from -10°C bis +160°C

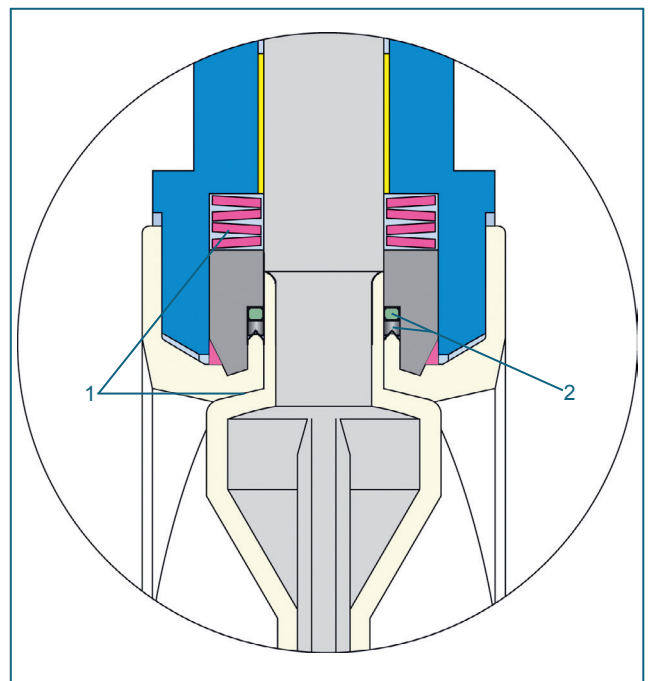

Safety seal at both shaft ends:

1. Primary sealing by means of a Belleville spring washer, transmitting prestress on the spherical segment area.
2. Secondary sealing of the shaft by means of PTFE-Chevron and O-ring.

PTFE-LINED BUTTERFLY VALVE T 211-A

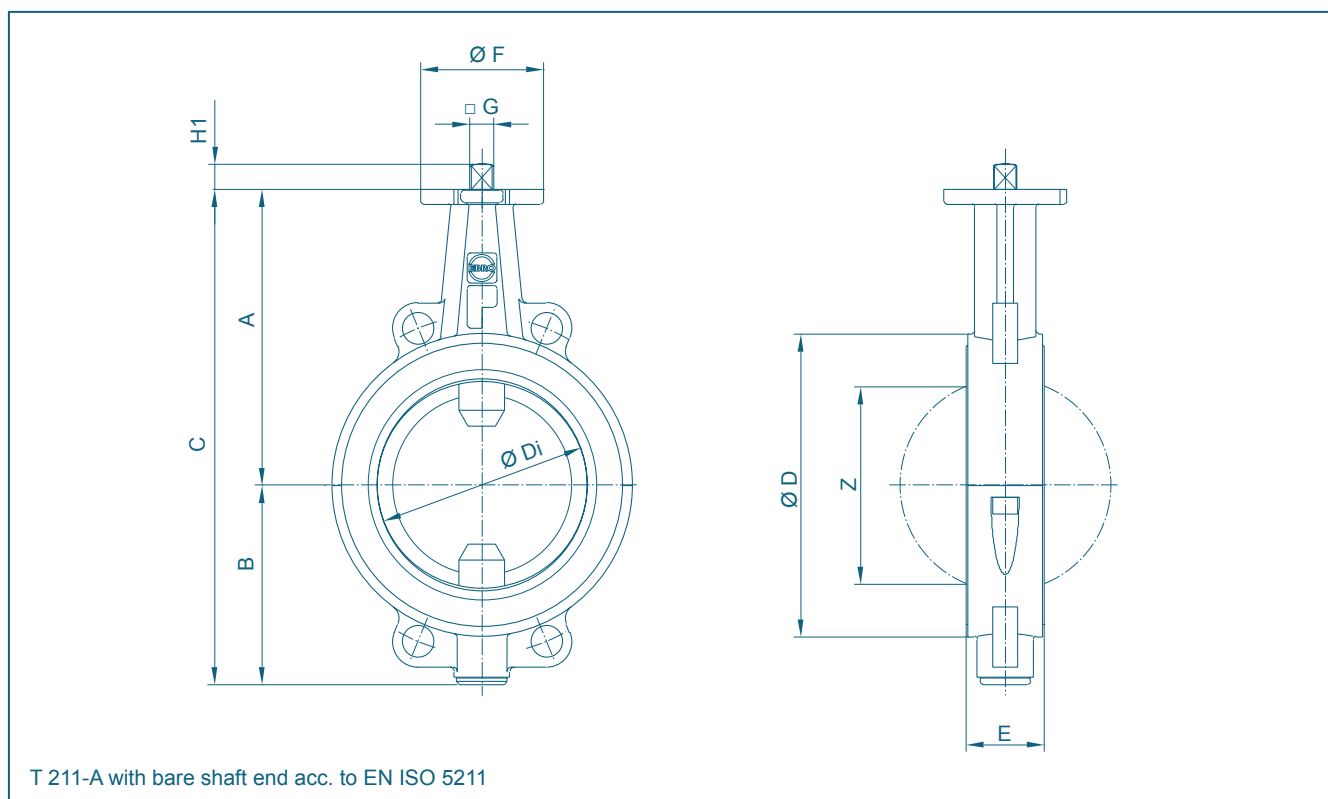

DN [mm]	Size [in]	Dimensions [mm]											Weight [kg]
		A	B	C	D	Di	E	F	Flange	G	H1	Z	
40*/50	2	135	80	215	112	60,8	46	54	F04	11	12	41	2,8
65	2½	150	82	232	120	60,8	46	54	F04	11	12	41	3,4
80	3	157	108	265	138	79,5	46	65	F05	14	16	66	4,5
100	4	180	118	298	160	99,0	52	65	F05	14	16	85	5,9
125	5	195	130	325	190	124,5	56	90	F07	17	19	112	8,1
150	6	210	142	352	215	150,5	56	90	F07	17	19	141	9,5
200	8	240	169	409	269	195,5	60	90	F07	17	19	187	15
250	10	275	217	492	324	247,5	68	125	F10	22	24	239	24
300	12	300	240	540	374	292,5	78	125	F10	22	24	283	34

*DN 50 drilled DN 40

Subject to change without notice

PTFE-LINED BUTTERFLY VALVE T 211-A

MATERIAL SPECIFICATION AND PARTS LIST

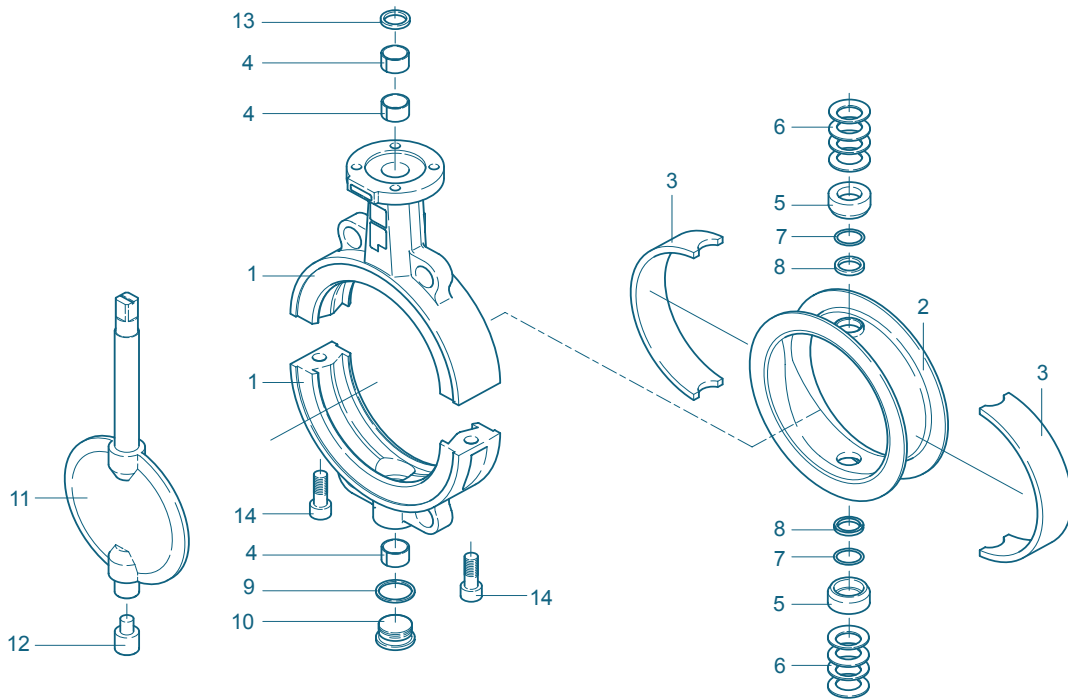

PTFE-lined butterfly valve DN 80 - DN 200

Pt.	Description	Material	Material-No.	ASTM	Pt.	Description	Material	Material-No.	ASTM
1	Body				8**	Chevron seal			
	Nodular Cast Iron	GGG-40.3	EN-JS 1025	A 395		PTFE	Polytetrafluorethylene	PTFE	PTFE
	Stainless Steel	G-X6CrNiMo18-10	1.4408	CF8M	9	Seal			
		X2CrNiMo17-12-2	1.4404	316 L		Stainless Steel	X5CrNi18-10	1.4301	304
2**	Seat				10	Plug screw DIN 908			
	PTFE	Polytetrafluorethylene	PTFE	PTFE *		Stainless Steel	G-X6CrNiMo18-10	1.4408	CF8M
3**	Elastomer insert				11***	Disc/Shaft	one-piece		
	Silicon	Silicon rubber	MVQ	VMQ		St.Steel/ St.Steel	G-X2CoNiMoN26-7-4	1.4469	Duplex
4	DU-bearing					St.Steel/ PTFE	G-X2CoNiMoN26-7-4	1.4469/	Duplex
	PTFE coated						Polytetrafluorethylene	PTFE	PTFE *
5**	Trust collar				12	Lower shaft stub			
	Stainless Steel	X5CrNiMo17-12-2	1.4401	316		Stainless Steel	X39CrMo17-1	1.4122	
6	Bellev. spr. washer				13	Wiper ring			
	Stainless Steel	X12CrNi177	1.4568	631		PTFE	Polytetrafluorethylene	PTFE	PTFE
7**	O-ring				14	Screw			
	FPM	Fluorocarbon caoutchouc	FPM	FKM		Stainless Steel	A4-70	1.4401	B8M
Above-mentioned materials of the basic version, other materials upon request									

* optional: electrically conductive

** recommended spare parts

*** recommended for coated discs

Subject to change without notice

PTFE-LINED BUTTERFLY VALVE T 211-A

TORQUE

- The torque values specified (Md) are based on dry media and are measured with air at a temperature of 20 °C
 - The values specified are based on the initial breakaway torque (disc disengages from seat, torque then drops)
 - Dynamic torque specification available upon request
- Regarding the dimensioning of actuators, please contact our engineers.

DN [mm]	40/50	65	80	100	125	150	200	250	300
Size [in]	2	2½	3	4	5	6	8	10	12
MD [Nm]	40	40	70	95	130	170	230	350	480

PRESSURE/TEMPERATURE DIAGRAM

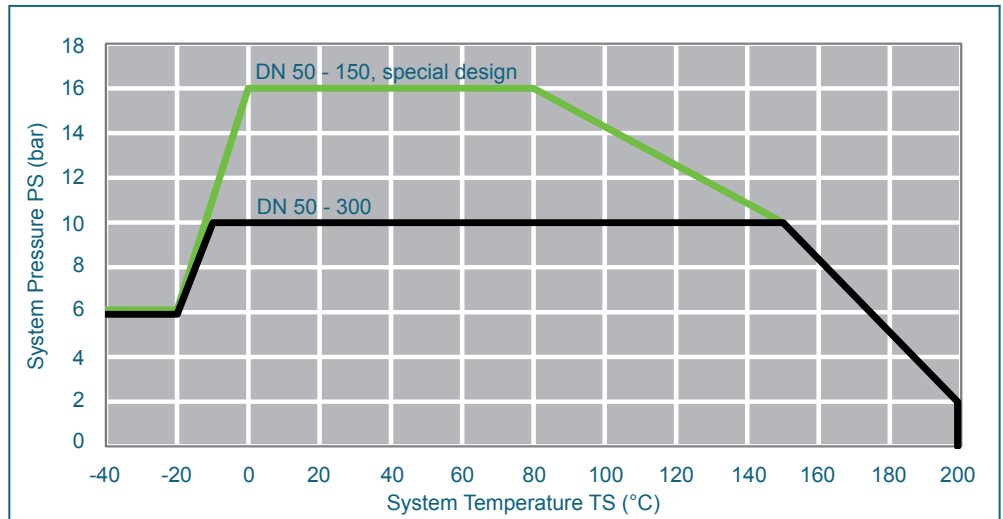

Pressure-Temperature-Diagram for valves with Silicone elastomer inserts

Service limitation with EPDM elastomer inserts from -10°C up to +120°C

Service limitation with Fluor carbon inserts (FPM) from -10°C up to +180°C

Vacuum service to 1mbar absolute, from -10°C up to +160°C. Valve installation between flanges

K_V-VALUES

- The K_V-value [m³ per hour] is the flow of water at a temperature of 5°C to 30°C (41°F to 86°F) at Δp of 1 bar
 - The K_V-values specified are based on tests carried out by the Delfter Hydraulics Laboratories, the Netherlands
 - Permissible velocity of flow
V_{max} 4,5 m/s for liquids,
V_{max} 70 m/s for gases
 - The throttle function is linear at an angle 30° to 70°
 - Avoid cavitation
- For further values, please contact our engineers.

DN [mm]	Size [in]	Opening angle α°							
		20°	30°	40°	50°	60°	70°	80°	90°
1) K_V-values metal disc									
40/50	2	4	2	11	28	53	84	121	161
65	2½	5	8	25	56	99	153	216	287
80	3	13	12	30	69	131	216	328	467
100	4	13	25	61	121	207	319	459	627
125	5	37	66	122	216	353	543	793	1111
150	6	50	94	171	303	509	810	1226	1778
200	8	137	149	344	696	1178	1764	2426	3137
250	10	178	291	562	1021	1699	2626	3832	5348
300	12	395	378	820	1638	2751	4079	5538	7049
2) K_V-values PTFE-disc									
40/50	2	2	1	4	12	22	35	50	67
65	2½	3	9	26	48	74	98	117	126
80	3	4	14	38	71	108	143	171	186
100	4	6	16	48	95	151	209	262	303
125	5	12	40	110	217	356	525	718	933
150	6	18	60	161	317	526	787	1096	1452
200	8	125	176	395	756	1234	1807	2449	3136
250	10	138	333	644	1103	1744	2599	3702	5086
300	12	203	462	872	1479	2329	3471	4950	6814

Subject to change without notice