

LUG TYPE PROCESS VALVE T 214-C

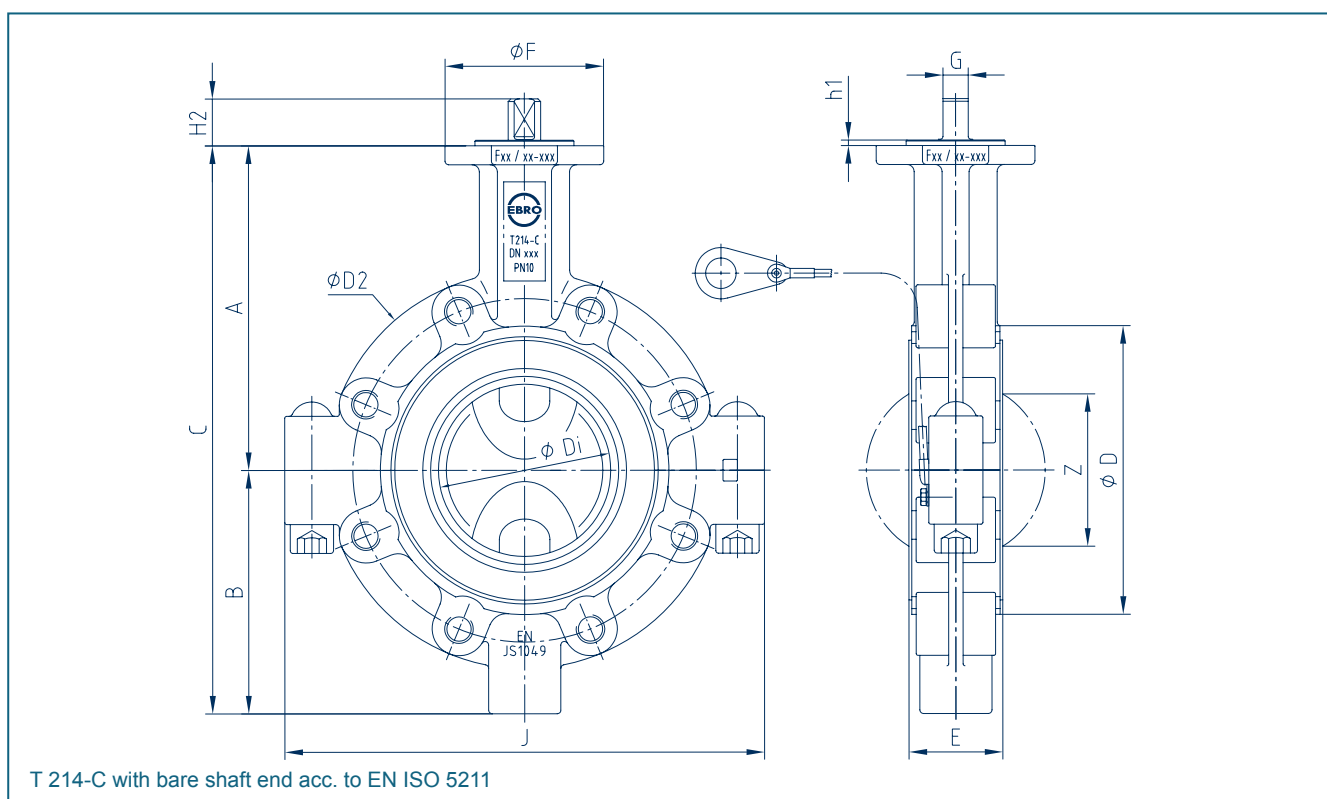

DN [mm]	Size [in]	Dimensions [mm]													Weight [kg]	
		A	B	C	ØD	ØD2	ØDi	E	Flange	ØF	G	h1	H2	J		Z
40/50	1½ 2	126	95	221	104	155	49	43	F07	90	11	3	22	167	25	4,5
65	2½	150	103	253	120	175	61	46	F07	90	11	3	22	181	41	5,5
80	3	157	124	281	138	190	80	46	F07	90	14	3	26	227	66	8,0
100	4	180	135	315	160	210	100	52	F07	90	14	3	26	266	85	10,0
150	6	210	167	377	212	280	151	56	F10	125	17	3	31	322	141	15,0
200	8	240	190	430	268	336	196	60	F12	150	17	3	31	390	187	27,0
250	10	275	232	507	324	412	248	68	F12	150	22	3	40,5	481	239	45,0
300	12	298	260	558	374	460	293	78	F14	175	22	4	41,5	558	283	69,0

Subject to change without notice

LUG TYPE PROCESS VALVE T 214-C

MATERIAL SPECIFICATION AND PARTS LIST

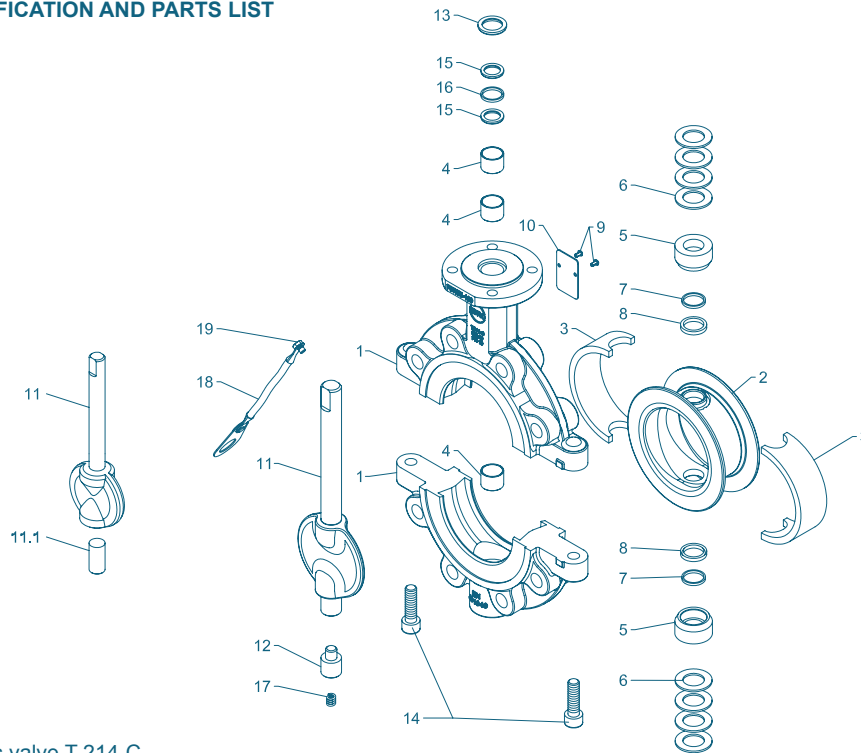

PTFE-lined process valve T 214-C

Pos.	Description	Material	Material-No.	ASTM	Pos.	Description	Material	Material-No.	ASTM
1	Body				11**	Shaft/Disc	one-piece		
	Nodular Cast Iron	EN-JS 1049	EN 1563	A395		St. Steel /St. Steel	GX2CrNiMoN26-7-4	1.4469	EN 10213
2**	Seat					St. Steel /St. Steel PFA	GX2CrNiMoN26-7-4	1.4469	
	PTFE	Polytetrafluorethylene	PTFE	PTFE *			Perfluoroalkoxy	PFA	PFA
3**	Elastomer insert				11.1	Lower shaft (DN 40/50 only)			
	Silicon	Silicon - rubber	MVQ	VMQ		Stainless Steel	X2CrNiMoN22-5-3	1.4462	Duplex
4	DU-bearing				12	Lower shaft stup (DN 65 - DN 200 only)			
	PTFE coated					Stainless Steel	X39CrMo 17-1	1.4122	
5**	Trust collar				13	Wiper ring			
	Stainless Steel	X5CrNiMo17-12-2	1.4401	316		PTFE	Polytetrafluorethylene	PTFE	PTFE
6	Belleville spring washer				14	Screw			
	Stainless Steel	X12CrNi177	1.4568	631		Stainless Steel	A4-70	1.4401	A193-B8
7**	O-Ring				15**	Thrust ring			
	FPM	Fluorocarbon caoutchouc	FPM	FKM		PTFE	Polytetrafluorethylene	PTFE	PTFE
8**	Chevron seal				16**	O-Ring			
	PTFE	Polytetrafluorethylene	PTFE	PTFE		FPM	Fluorocarbon caoutchouc	FKM	
9	Groove pin				17	Spiral spring			
	Stainless Steel	A2				Spring steel	X10CrNi 18-8	1.4310	301
10	Type plate				18	Buttstrap			
	Stainless Steel								
					19	Screw			
						Stainless Steel	A2-70		A193-B8

* optional: electrically conductive

** recommended spare parts

Subject to change without notice

LUG TYPE PROCESS VALVE T 214-C

TORQUE

- The torque values specified (Md) are based on dry media and are measured with air at a temperature of 20 °C
- The values specified are based on the initial breakaway torque (disc disengages from seat, torque then drops)
- Dynamic torque specification available upon request

Regarding the dimensioning of actuators, please contact our engineers.

PRESSURE/TEMPERATURE DIAGRAM

DN (mm)	40/50	65	80	100	150	200	250	300
Size (in)	1½ 2	2½	3	4	6	8	10	12
MD (Nm)	35	35	55	70	135	170	320	380
MAST (Nm)*	105	105	250	250	480	480	1020	1020

*Maximum torques (Nm)

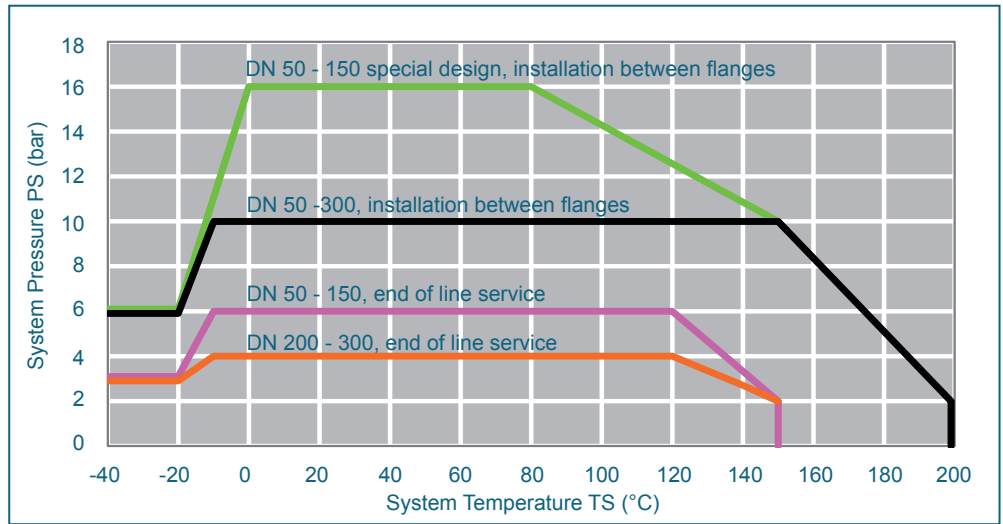

Pressure-Temperature-Diagram for valves with Silicone elastomer inserts

Service limitation with Fluor carbon inserts (FPM) from -10°C up to +120°C

Service limitation with EPDM elastomer inserts from -10°C up to +180°C

Vacuum service to 1mbar absolute, from -10°C up to +160°C. Valve installation between flanges

K_V-VALUES

- The K_V-value [m³ per hour] is the flow of water at a temperature of 5°C to 30°C (41°F to 86°F) at Δp of 1 bar
- The K_V-values specified are based on tests carried out by the Delfter Hydraulics Laboratories, the Netherlands
- Permissible velocity of flow
V_{max} 4,5 m/s for liquids,
V_{max} 70 m/s for gases

- The throttle function is linear at an angle 30° to 70°

- Avoid cavitation

For further values, please contact our engineers.

DN [mm]	Size [in]	Opening angle α°							
		20°	30°	40°	50°	60°	70°	80°	90°
1) K_V-values metal disc									
40/50	1½ 2	4	5	16	35	57	81	101	114
65	2½	5	8	25	56	99	153	216	287
80	3	13	12	30	69	131	216	328	467
100	4	13	25	61	121	207	319	459	627
150	6	50	94	171	303	509	810	1226	1778
200	8	137	149	344	696	1178	1764	2426	3137
250	10	178	291	562	1021	1699	2626	3832	5348
300	12	395	378	820	1638	2751	4079	5538	7049
2) K_V-values PFA-disc									
40/50	1½ 2	2	4	13	25	40	53	63	66
65	2½	3	9	26	48	74	98	117	126
80	3	4	14	38	71	108	143	171	186
100	4	6	16	48	95	151	209	262	303
150	6	18	60	161	317	526	787	1096	1452
200	8	125	176	395	756	1234	1807	2449	3136
250	10	138	333	644	1103	1744	2599	3702	5086
300	12	203	462	872	1479	2329	3471	4950	6814

Subject to change without notice