

HIGH PERFORMANCE BUTTERFLY VALVE HP 114-K3



Lug type butterfly valve in double-eccentric construction. Reliable sealing even with extreme temperature and pressure conditions.

TECHNICAL DATA

Nominal diameter:	DN 50 - DN 600 (larger nominal diameter on request)
Face-to-face:	EN 558 Series 16 ISO 5752 Series 16
Flange accommodation:	EN 1092 PN 10/16/25/40 (to DN 150) EN 1092 PN 10/16/25 (DN 200-DN 600) ASME Class 150/300 AS 4087 PN16/21
Flange Surface Design:	EN 1092, Form A/B, ASME RF,FF
Top flange:	EN ISO 5211
Marking:	EN 19
Tightness check	
- for R-PTFE seat:	EN 12266 (Leakage rate A)
- for Inconel seat:	EN 12266 (Leakage rate B) ISO 5208, Category 3
Temperature range:	-60°C to +600°C
Differential pressure:	≤ DN150 max. 40 bar > DN150 max. 25 bar
Vacuum:	up to 1mbar absolute

FEATURES

- Shut-off and control of gaseous and liquid media
- Disc and shaft have double-eccentric bearing
- Centering pieces can be used as installation aid
- Two seat ring systems available: R-PTFE and Inconel
- Seal variants:
 - soft-sealing (R-PTFE) max. 230°C
 - metallic sealing (Inconel) max. 600°C
- Maintenance-free
- Long service life, even at high switching frequencies
- FIRE SAFE BS 6755 PART 2

GENERAL APPLICATIONS

- Chemical and petrochemical industries
- Hot water and steam systems
- District heat supply
- Vacuum systems
- Shipbuilding
- Gas process technology
- Food industry
- Heavy duty services

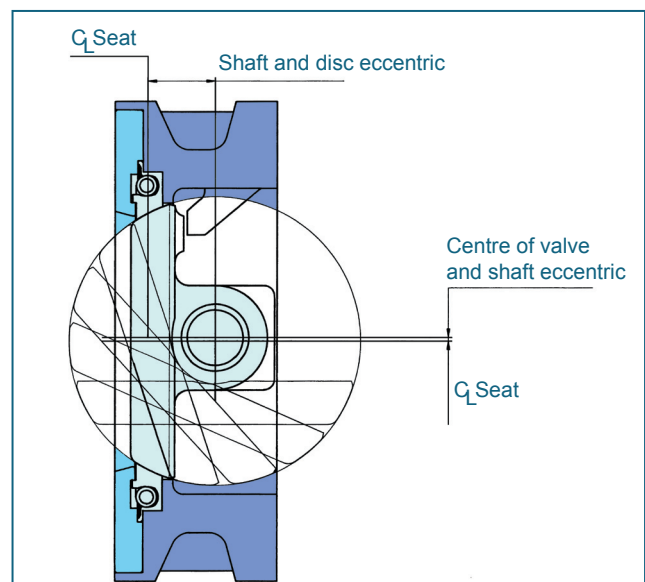

HIGH PERFORMANCE BUTTERFLY VALVE HP 114-K3

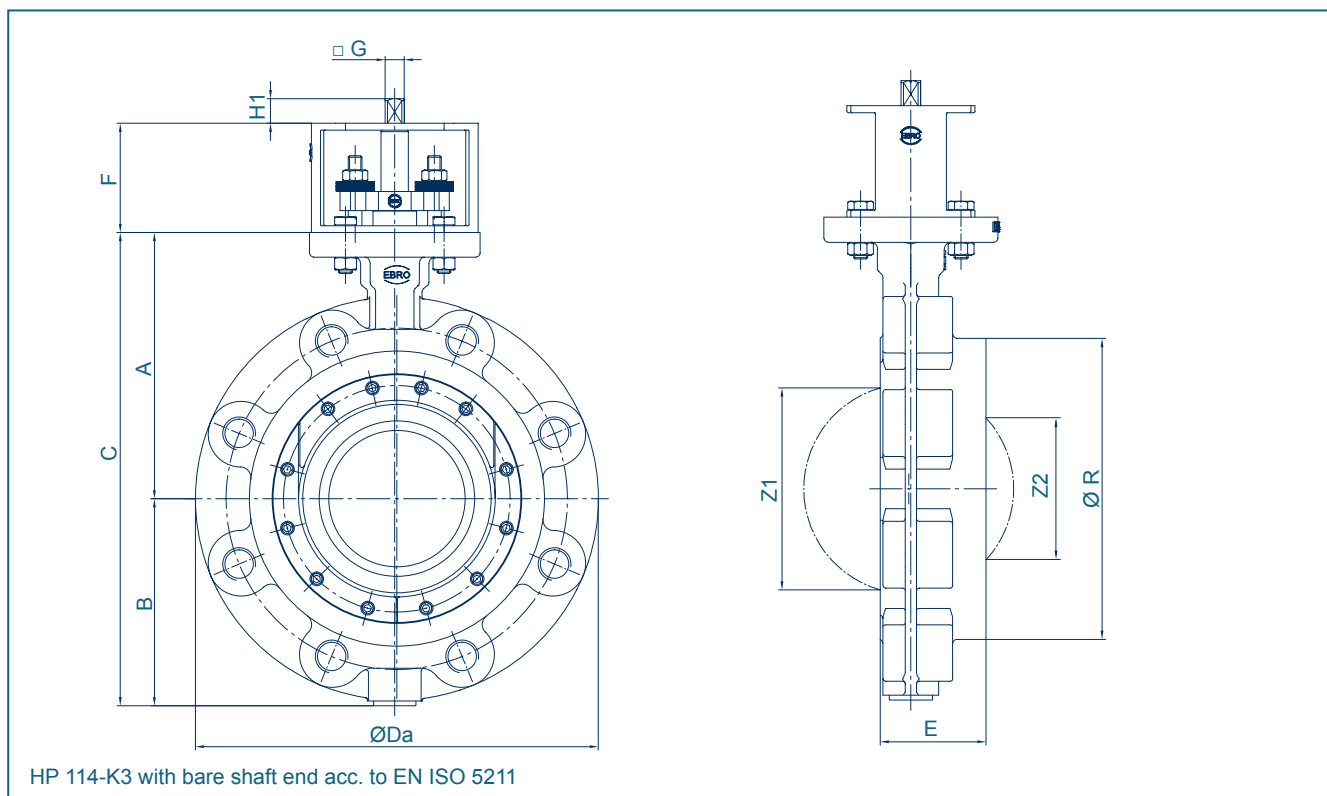

DN [mm]	Size [in]	Dimensions [mm]											Weight [kg]	
		A	B	C	Ø Da	E	F	Flange	□ G	H1	Ø R	Z1		Z2
50	2	133	96	229	180	64	80	F07	12	15	112	41	-	8
65	2½	133	96	229	180	64	80	F07	12	15	112	41	-	9
80	3	142	110	252	200	65	80	F07	12	15	138	71	-	12
100	4	158	122	280	235	65	80	F07	12	15	160	95	49	14
125	5	181	138	319	260	70	80	F10	14	15	190	115	76	19
150	6	195	152	347	295	76	80	F10	14	15	216	144	102	24
200	8	225	189	414	352	89	80	F12	17	18	270	188	143	39
250	10	268	220	488	425	114	80	F12	22	23	326	236	171	61
300	12	300	253	553	485	114	90	F14	27	28	395	281	242	92
350	14	346	305	651	542	127	100	F14	27	28	438	323	281	125
400	16	375	340	715	606	140	100	F16	36	36	500	372	328	164
450	18	412	350	762	656	152	120	F16	36	36	530	427	397	189
500	20	425	400	825	716	152	120	F16	46	46	598	469	445	243
600	24	490	469	959	834	178	200	F25	55	55	708	545	516	270

Subject to change without notice

HIGH PERFORMANCE BUTTERFLY VALVE HP 114-K3

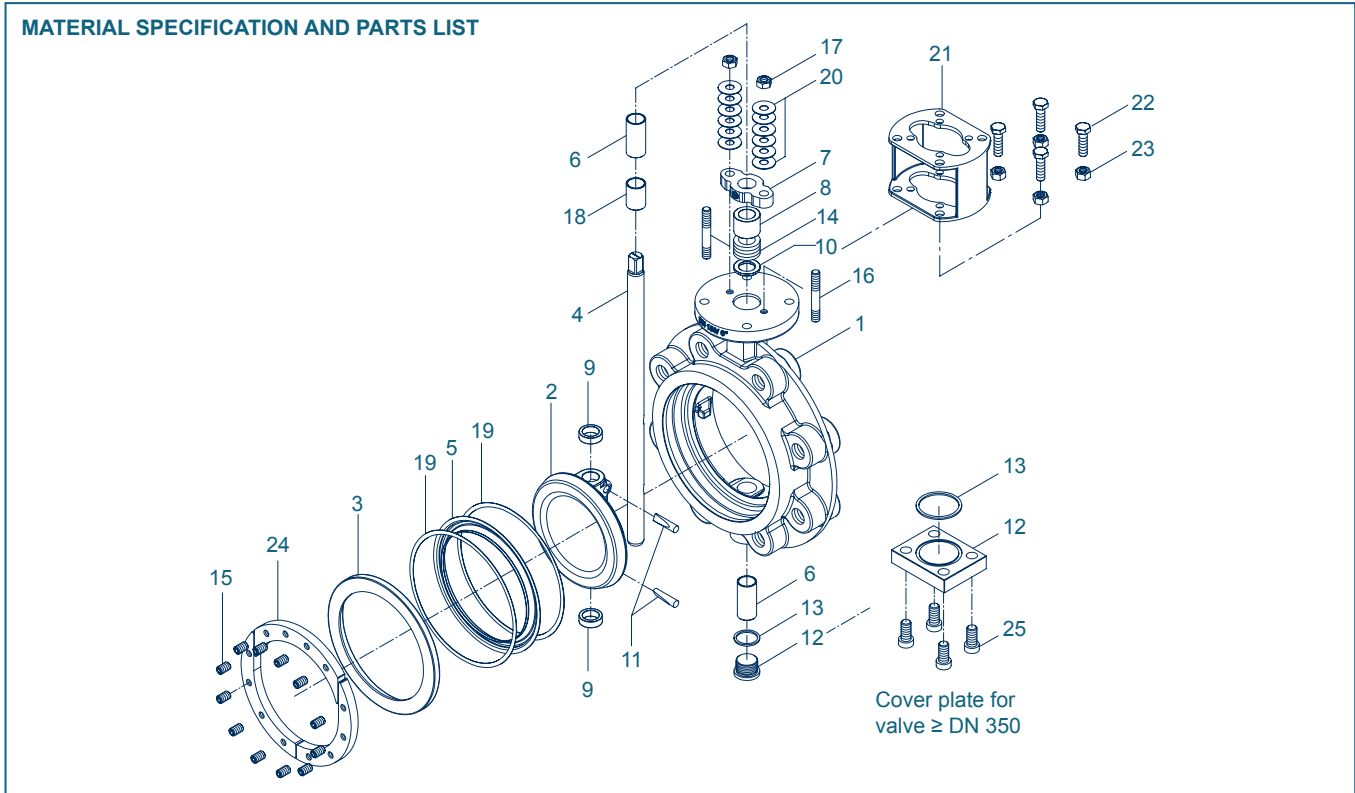

Pt.	Description	Material	Material No.	ASTM	Pos.	Description	Material	Material No.	ASTM					
1	Body	Carbon Steel	GS-C25N	1.0619	WCB	12	Plug screw (≤ 300)	Stainless Steel	G-X5CrNiMo19-11-2	1.4408	CF8M			
		Stainless Steel	G-X5CrNiMo19-11-2	1.4408	CF8M			12	Cover plate (≥350)	Stainless Steel	G-X5CrNiMo19-11-2	1.4408	CF8M	
		Duplex Steel	GX2CrNiMoN26-7-4	1.4469	Duplex Steel					GX2CrNiMoN26-7-4	1.4469			
2	Disc	Stainless Steel	G-X5CrNiMo19-11-2	1.4408	CF8M	13	Seal	PTFE						
		Duplex Steel	GX2CrNiMoN26-7-4	1.4469	Graphite									
3	Clamping ring	Steel	St37-2	1.0037	283-C	14	Shaft seal	PTFE						
		Stainless Steel	X5CrNiMo17-12-2	1.4401	316			Graphite						
		Duplex Steel	GX2CrNiMoN26-7-4	1.4469	15			Hexagon socket set screw with flat point	Stainless Steel	A4-70	B8M			
4	Shaft	Stainless Steel	X4CrNiMo16-5	1.4418		16	Threaded pin		Stainless Steel	A4-70	B8M			
		Duplex Steel	GX2CrNiMoN26-7-4	1.4469					17	Hexagon Nut	Stainless Steel	A4-70	B8M	
5	Seat ring	R-PTFE	PTFE-Compound		18	Distance bush	Stainless Steel	X10CrNi18-8			1.4310	301 Ti		
		Inconel	Inconel 625				Duplex Steel	GX2CrNiMoN26-7-4	1.4469					
		6	Shaft bearing	Stainless Steel			X5CrNiMo17-12-2	1.4401/PTFE	316 PTFE	20	Belleville spring washer	50CrV4	1.4310	
Stainless Steel	X6CrNiMoTi17-12-2			1.4571	nitrite	316 Ti								
Duplex Steel	GX2CrNiMoN26-7-4			1.4469	chr-plt									
7	Gland flange	Stainless Steel	G-X5CrNiMo19-11-2	1.4408	CF8M	21	Bracket	≤ DN 250 St. Steel	G-X5CrNiMo19-11-2	1.4408	CF8M			
		Duplex Steel	GX2CrNiMoN26-7-4	1.4469	≥ DN 300			St37-2	1.0037	zinc plated C				
		8	Thrust collar	Stainless Steel	X5CrNiMo17-12-2			1.4401	304	22	Hexagon bolt	Stainless Steel	A4-70	B8M
Stainless Steel	X2CrNiMo17-12-2			1.4404	304	23	Hexagon Nut	Stainless Steel	A4-70			B8M		
Stainless Steel	X6CrNiMoTi17-12-2			1.4571	316 Ti			24	Thrust ring			Stainless Steel	A4-70	B8M
9	Bearing ring	Stainless Steel	X6CrNiMoTi17-12-2	1.4571	chr-pld.	316 Ti	25			Hexagon-socket screw	Stainless Steel	A4-70	B8M	
		10	Suppor. washer	Stainless Steel	X6CrNiMoTi17-12-2	1.4571		316 Ti	25		Hexagon-socket screw	Stainless Steel	A4-70	B8M
				Duplex Steel	GX2CrNiMoN26-7-4	1.4469								
11	Taper pin	Stainless Steel	X4CrNiMo16-5	1.4418										
		Duplex Steel	GX2CrNiMoN26-7-4	1.4469										

Subject to change without notice

HIGH PERFORMANCE BUTTERFLY VALVE HP 114-K3

TORQUE

- The values specified are based on the initial breakaway torque. (disc disengages from seat, torque then drops)

DN [mm]	Size [in]	Operating pressure							
		10 [bar]		16 [bar]		25 [bar]		40 [bar]	
		R-PTFE	Inconel	R-PTFE	Inconel	R-PTFE	Inconel	R-PTFE	Inconel
50-65	2-2½	27	35	28	42	30	58	31	66
80	3	28	55	30	65	34	90	38	100
100	4	51	90	61	100	80	120	93	140
125	5	63	150	83	172	95	220	125	285
150	6	125	170	136	220	168	300	220	360
200	8	205	350	260	430	280	505	*	*
250	10	485	505	550	620	600	860	-	-
300	12	584	740	700	970	855	1280	-	-
350	14	740	815	930	1050	1200	1370	-	-
400	16	1050	1530	1640	2240	2460	2900	-	-
450	18	1150	1700	1750	2500	2700	3500	-	-
500	20	1210	2010	1800	2760	2800	4260	-	-
600	24	4000	4500	4600	5740	6200	8080	-	-

* DN 200 PN 16 max. 25 bar

All values in Nm

PRESSURE/TEMPERATURE DIAGRAM

- Pressure control line for 1.0619 body material and metal seat
- Pressure control line for 1.4408 body material and metal seat
- - - Pressure control line for R-PTFE

The diagram illustrates the performance of the standard version of our valve type HP. Valves for higher pressure or deviating temperature are available upon request.

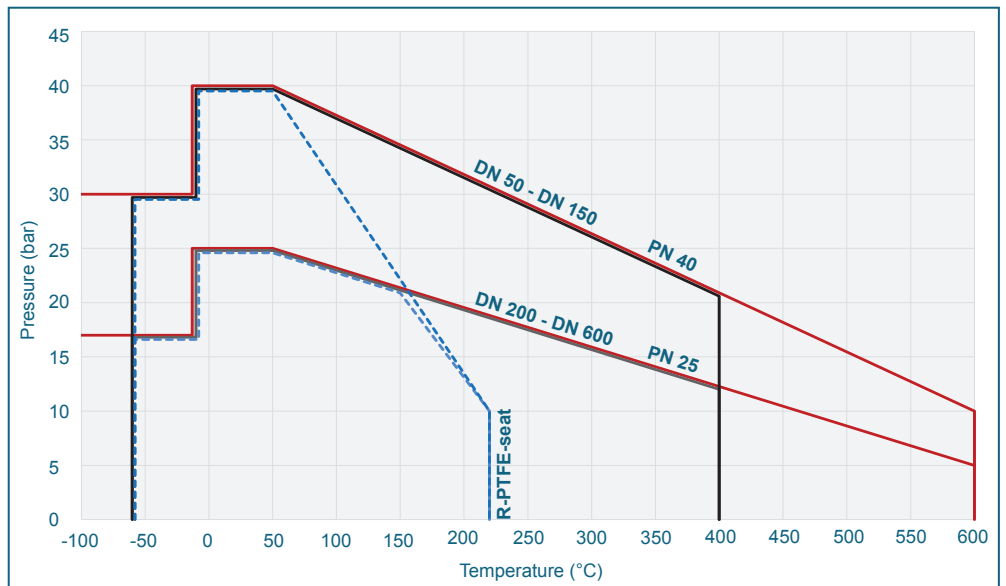

K_V-VALUES

- The K_V-value [m³ per hour] is the flow of water at a temperature of 5°C to 30°C (41°F to 86°F) at Δp of 1 bar

- The K_V-values specified are based on tests carried out by the Delfter Hydraulics Laboratories, the Netherlands

- Permissible velocity of flow
V_{max} 4,5 m/s for liquids,
V_{max} 70 m/s for gases

- The throttle function is linear at an angle 30° to 70°

- Avoid cavitation!

For further values, please contact our engineers.

DN [mm]	Size [in]	Opening angle α°							
		20°	30°	40°	50°	60°	70°	80°	90°
50	2	1,3	6	15	18	19	21	22	23
65	2½	1,5	7	18	22	23	24	25	25
80	3	7	30	50	68	82	97	113	115
100	4	22	60	97	119	164	199	223	251
125	5	45	100	152	195	256	346	452	493
150	6	63	109	162	250	391	588	814	845
200	8	96	168	301	509	742	1107	1581	1747
250	10	264	458	682	980	1421	2083	2882	2889
300	12	397	625	956	1368	1938	2778	3794	3940
350	14	460	720	1100	1650	2500	3400	4800	5400
400	16	550	870	1250	2000	3200	4800	6800	8080
450	18	730	1200	1800	3100	4600	6400	8400	10500
500	20	920	1600	2600	4100	6000	8500	12100	12800
600	24	1370	2250	3780	4950	9000	12500	17100	18500

Subject to change without notice